

Installation and Assembly Instructions



Gared Holdings, LLC
 9200 E. 146th St.
 Noblesville, IN 46060

21' ALUMINUM TIP & ROLL BLEACHER 4 ROW LOW RISE WITH SINGLE FOOT PLANK

FILE LOC. Q:\Inventor Files\Installation Instructions\490,000,000

| DATE | SHT. NO. | PART NO. | REV |
|-----------|----------|--------------|-----|
| 4/18/2014 | 1 OF 6 | TRB0421LR ai | |

Introduction/Liability Disclaimers

Thank you for your purchase of the Tip & Roll Aluminum Bleachers. This guide will provide information on the proper assembly and installation methods of your bleachers.

Please note that a Bill of Materials is being included with this guide. Please check that all of the parts called out on the Bill of Materials are present prior to beginning assembly. Please do not substitute for factory parts. Please contact the PSS or Gared Sports customer service department and allow them to determine if substitute parts are acceptable.

It is recommended that an individual who has been properly trained perform assembly and set up of the bleachers. No one under the age of 18 should attempt assembly or set up of the unit, unless properly supervised.

To prevent normal wear and tear from shortening the life of the unit, preventative maintenance inspections and repairs should be performed at least once per year. If the units are subject to high or unusual usage, inspections should be scheduled to occur more frequently. If items are found to be nonconforming, replacements can be ordered from PSS or Gared Sports or one of our authorized dealers. When contacting PSS or Gared Sports, please have information regarding the dealer/installer who sold the unit, the name of the project, and any applicable warranty information.

800-325-2682 -- Gared Customers
800-848-8034 -- PSS Customers

Installation and Assembly Instructions



Gared Holdings, LLC
9200 E. 146th St.
Noblesville, IN 46060

21' ALUMINUM TIP & ROLL BLEACHER 4 ROW LOW RISE WITH SINGLE FOOT PLANK

FILE LOC. Q:\Inventor Files\Installation Instructions\490,000,000

| DATE | SHT. NO. | PART NO. | REV |
|-----------|----------|--------------|-----|
| 4/18/2014 | 2 OF 6 | TRB0421LR ai | |

| MATERIAL LIST | | | | |
|---------------|-----|----------------|-----------------------------------|-----------|
| ITEM | QTY | PART NUMBER | DESCRIPTION | LENGTH |
| 1 | 3 | 198011026-21 | PLANK, FOOT 10" MILL FINISH X 21' | 252.00 in |
| 2 | 4 | 198011031-21AN | PLANK, SEAT 12" ANNODIZED X 21' | 252.00 in |
| 3 | 6 | 498011030 | BRACE ANGLE - 75.44 LONG | |
| 4 | 6 | 498011033 | END CAP, BLEACHER SEAT | |
| 5 | 56 | 498011035 | MOUNTING CLIP | |
| 6 | 8 | 498011037 | CASTER - 4 X 1 1/4 POLY RIGID | |
| 7 | 20 | 498011078 | RUBBER PAD | |
| 8 | 3 | 498011092 | BRACE ANGLE - 74.00" LONG | |
| 9 | 4 | 498011093 | FRAME, 4 ROW LOW RISE TIP & ROLL | |
| 10 | 8 | 498011243 | END CAP, 12" BLEACHER PLANK | |
| 11 | 40 | 6044-11-00 | 1/8" POP RIVET | |
| 12 | 56 | 501-5-18-24 | BOLT, CARRIAGE 5/16-18 UNC X 1.5 | |
| 13 | 32 | 502-5-18-16 | HEX BOLT, 5/16-18 UNC X 1 | |
| 14 | 20 | 502-5-18-20 | HEX BOLT, 5/16-18 UNC X 1.25 | |
| 15 | 15 | 502-6-16-16 | HEX BOLT, 3/8-16 UNC X 1 | |
| 16 | 20 | 545-5-18Z | HEX NUT, NYLON LOCK 5/16-18 | |
| 17 | 88 | 548-5-18Z | HEX NUT, SERRATED FLANGE 5/16-18 | |
| 18 | 15 | 548-6-16 | HEX NUT, SERRATED FLANGE 3/8-16 | |
| 19 | 20 | 561-5 | FLAT WASHER 5/16 | |

1. Pre-assemble the braces by laying them out in pairs. Place the angles in each pair back to back and connect with a 3/8" x 1" hex bolt and 3/8" Whizlock nut as shown in Figure 1.

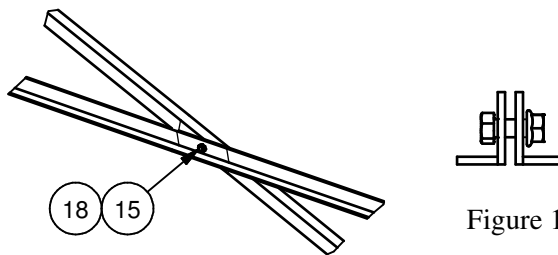
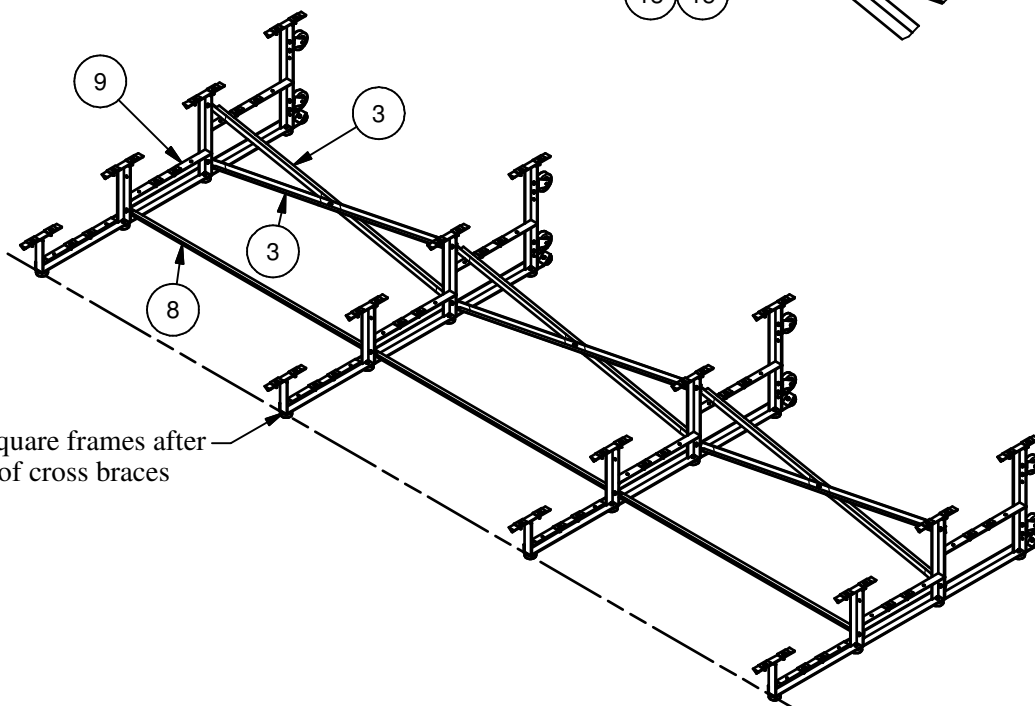

Figure 1



Align and square frames after installation of cross braces

Installation and Assembly Instructions



Gared Holdings, LLC
9200 E. 146th St.
Noblesville, IN 46060

21' ALUMINUM TIP & ROLL BLEACHER 4 ROW
LOW RISE WITH SINGLE FOOT PLANK

FILE LOC. Q:\Inventor Files\Installation Instructions\490,000,000

| | | | |
|-----------|----------|--------------|-----|
| DATE | SHT. NO. | PART NO. | REV |
| 4/18/2014 | 3 OF 6 | TRB0421LR ai | |

2. Pre-assemble the frames with the rubber pads and caster assemblies. Install a rubber foot at each hole location under the seat vertical and the angled position at the rear of the frame. Use the 5/16" x 1-1/4" hex bolt, 5/16" flat washer between the head of the bolt and the rubber pad, and a 5/16 nylon lock nut (see figure 2). Attach two caster assemblies to each frame (see figure 3). Use the 5/16" x 1" hex bolts and 5/16" whizlock nuts. Four bolts and nuts are required for each caster assembly.

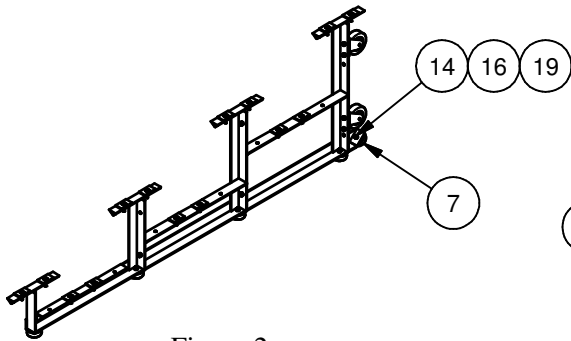

Figure 2

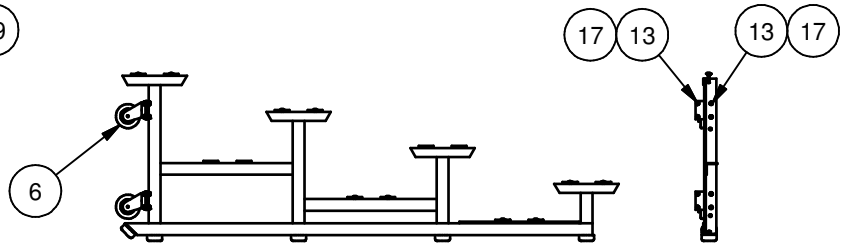

Figure 3

3. Lay out the Frame weldments approximately 4'-6" apart. Install the brace sub-assemblies from step 1 using the 3/8" x 1" hex bolts and 3/8" whizlock nuts as shown in Figure 4. Install the straight brace using the 3/8" x 1" hex bolt and 3/8" whizlock nut as shown in Figure 4.

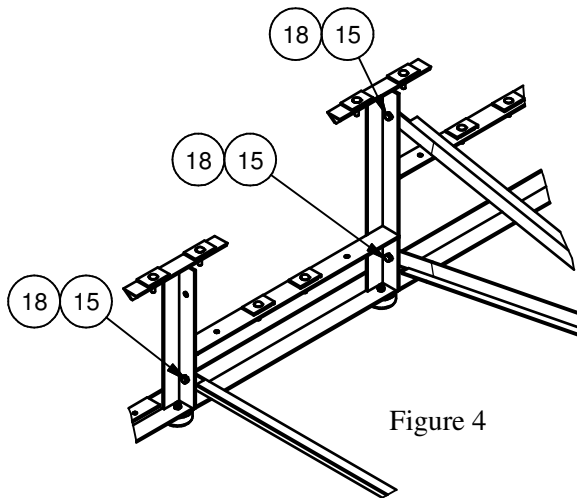

Figure 4

4. Install the end caps on each end of the seat planks, foot planks, and riser planks. Slide the end cap onto the plank with the holes on the underside of the plank. Using the holes in the end cap for a guide, drill a 1/8" hole and install the pop rivets to retain the end caps. See Figure 5.

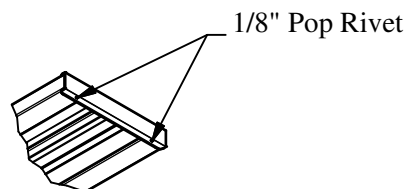

Figure 5

Installation and Assembly Instructions



Gared Holdings, LLC
9200 E. 146th St.
Noblesville, IN 46060

21' ALUMINUM TIP & ROLL BLEACHER 4 ROW LOW RISE WITH SINGLE FOOT PLANK

FILE LOC. Q:\Inventor Files\Installation Instructions\490,000,000

| DATE | SHT. NO. | PART NO. | REV |
|-----------|----------|--------------|-----|
| 4/18/2014 | 4 OF 6 | TRB0421LR ai | |

5. Install the foot planks using the mounting clips, 5/16" carriage bolts, and 5/16" Whizlock. These mounting clips, bolts, and nuts are required at every frame position. Pre-install the mounting clips on the frame using the 5/16" x 1" carriage bolt and 5/16" whizlock nut. Only start the nuts a few threads to allow for the clips to be lifted and rotated into the channel of the bleacher plank.

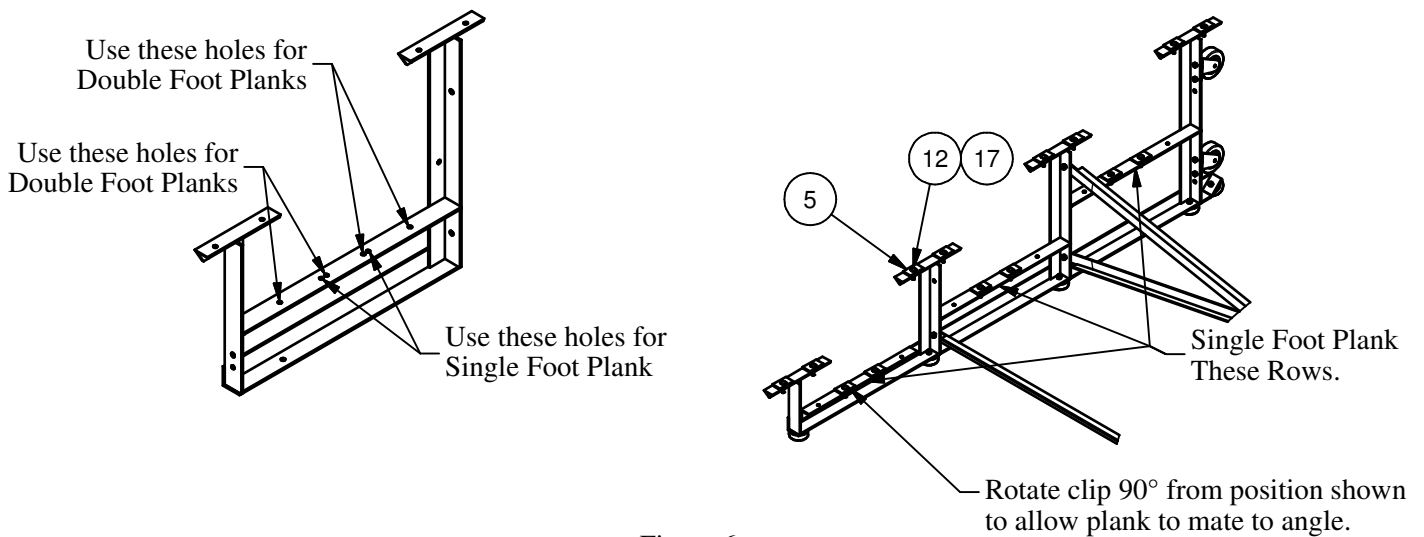
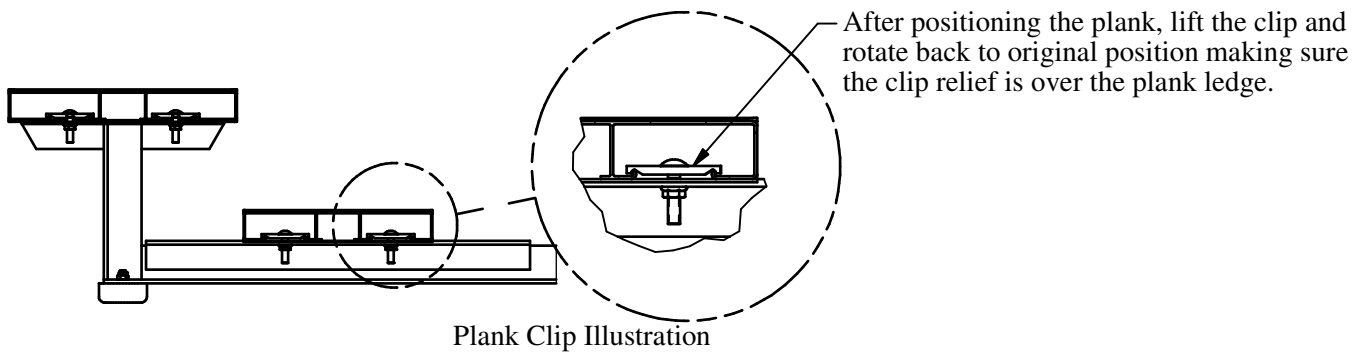

Figure 6

Note: Single foot planks are used on all foot rows. Install all foot planks before installing the seat planks.



6. Before tightening the foot plank bolts, align all the planks and make sure the planks are centered on the assembled frame. See Figure 7 for reference dimensions.

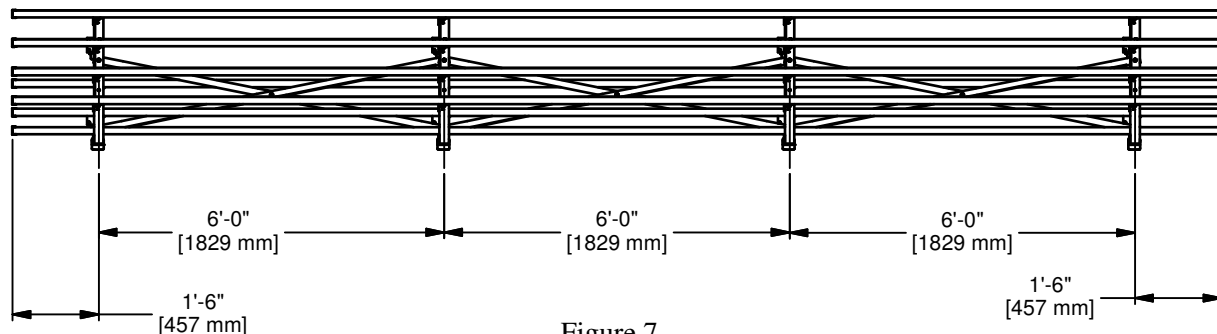

Figure 7

Installation and Assembly Instructions



Gared Holdings, LLC
9200 E. 146th St.
Noblesville, IN 46060

21' ALUMINUM TIP & ROLL BLEACHER 4 ROW LOW RISE WITH SINGLE FOOT PLANK

FILE LOC. Q:\Inventor Files\Installation Instructions\490,000,000

| DATE | SHT. NO. | PART NO. | REV |
|-----------|----------|--------------|-----|
| 4/18/2014 | 5 OF 6 | TRB0421LR ai | |

7. Install the seat planks using the mounting clips, 5/16" x 1" carriage bolts, and 5/16" whizlock as shown in figure 4. Note: these mounting clips, bolts, and nuts are required at every frame position.

8. Before tightening the seat plank bolts, align all the planks and make sure the planks are centered on the assembled frame. See Figure 5 for reference dimensions.

9. Check all bolted connections and insure all bolts are securely tightened.

The bleacher assembly is now complete. Position the bleacher into the desired location and anchor as required by local codes.

Installation and Assembly Instructions



Gared Holdings, LLC
9200 E. 146th St.
Noblesville, IN 46060

21' ALUMINUM TIP & ROLL BLEACHER 4 ROW LOW RISE WITH SINGLE FOOT PLANK

FILE LOC. Q:\Inventor Files\Installation Instructions\490,000,000

| DATE | SHT. NO. | PART NO. | REV |
|-----------|----------|--------------|-----|
| 4/18/2014 | 6 OF 6 | TRB0421LR ai | |